

Ciběs



NEW GENERATION HOME LIFT

CIBES – SINCE 1947

Cibes Lift Group is one of the world's largest manufacturers of low-speed lifts, with sales and distribution in more than 70 countries, and a network of 200+ certified distributors.



WHAT MAKES CIBES SPECIAL?

DIRECT SALES ACROSS THE WORLD

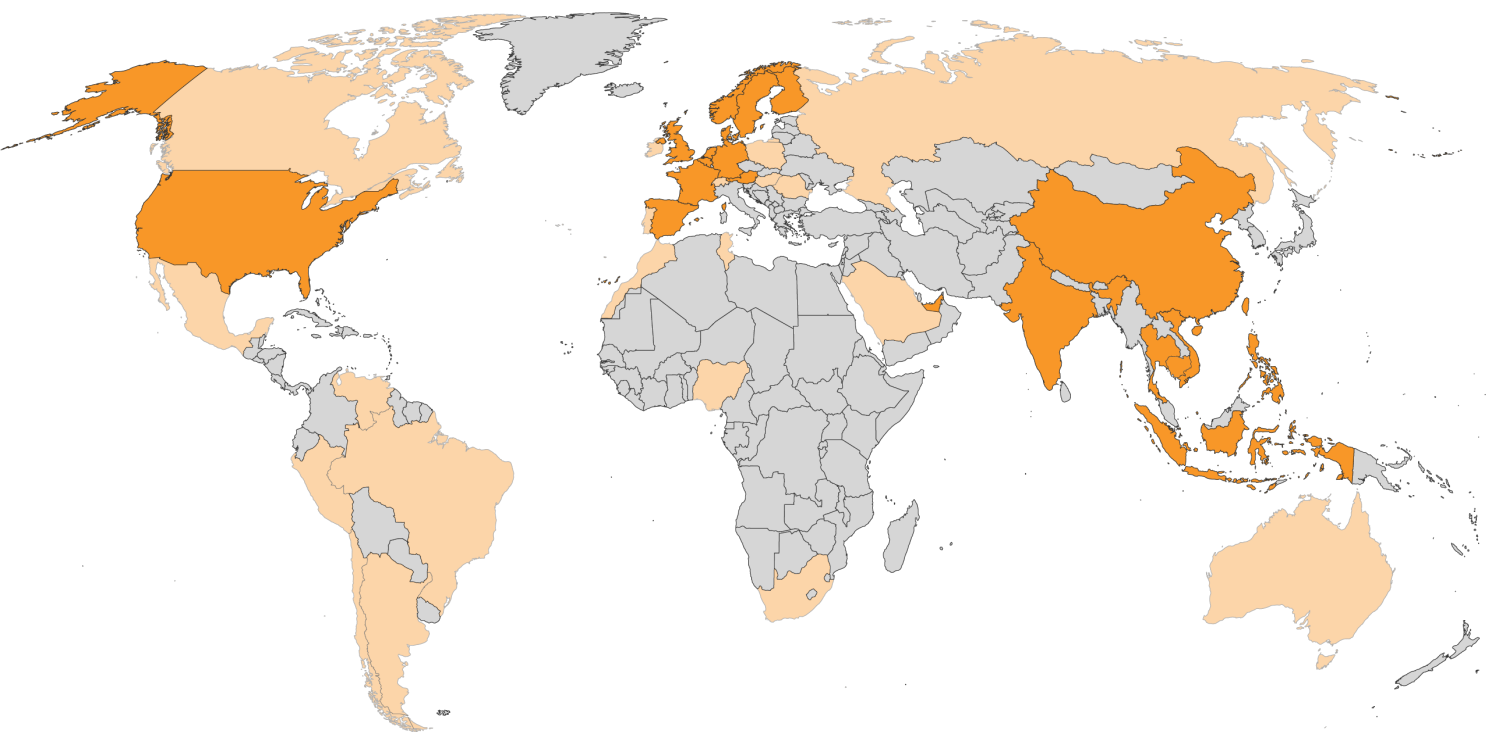

FACTORY DIRECT SUBSIDIARIES IN:

SWEDEN | NORWAY | FINLAND | FRANCE | UNITED KINGDOM | GERMANY | HOLLAND | SPAIN | AUSTRIA | BELGIUM | DUBAI | CHINA | VIETNAM | **PHILIPPINES** | CAMBODIA | INDONESIA | THAILAND | INDIA | USA

WORDS FROM OUR CEO,
PER LIDSTRÖM



One does not build a company that lasts over 70 years without an unwavering commitment to customer satisfaction. Cibes fully embraces the Scandinavian ethos of reliability, which is why we are uncompromising when it comes to the quality of our products, the elegance of our designs and our commitment to safety. From the start, our best marketing has always been our existing customers, and the 50,000 lifts we have installed around the world continue to be a driver of our success. At Cibes, we know that our happy customers are the key to our longevity, and we look forward to having you join the Cibes family!

Per Lidström

CEO, CIBES LIFT GROUP

ABOUT

CIBES LIFT GROUP IN 2023

290

MILLION EUROS
In turnover in 2023

1,635

EMPLOYEES
Across the world

100,000+

LIFTS INSTALLED
In 70+ countries

SPACE - SAVING TECHNOLOGY

NO MACHINE ROOM

Minimize civil works and able to open up on last floor without damage to roof area

ALL GLASS SHAFT

Able to do 360 glass shaft for a panoramic ride

SCREW DRIVE SYSTEM

Your lift is always attached to our screw and cannot "fall down".
Silent and energy efficient

SUPERIOR QUALITY

From our glass (laminated and tempered) to our shaft (aviation grade aluminum with premium custom powdercoat), every detail of our lift is carefully studied to offer the best quality.

TOUCH AND LIGHT

Our Cibes lifts come with full touchscreen to offer a modern design that can match any interior

PLATFORM DESIGN

Our lifts are platform lifts, which saves space, creates a feeling of openness and avoids locking you inside a cabin.

ANTI-STUCK SYSTEM

Battery back up, reset tag on door, phone and emergency openings – we have you covered even if the worst were to happen!

NO PIT

Installing our lift is simple – it requires no pit and can be installed straight on the floor with only a 50 mm ramp

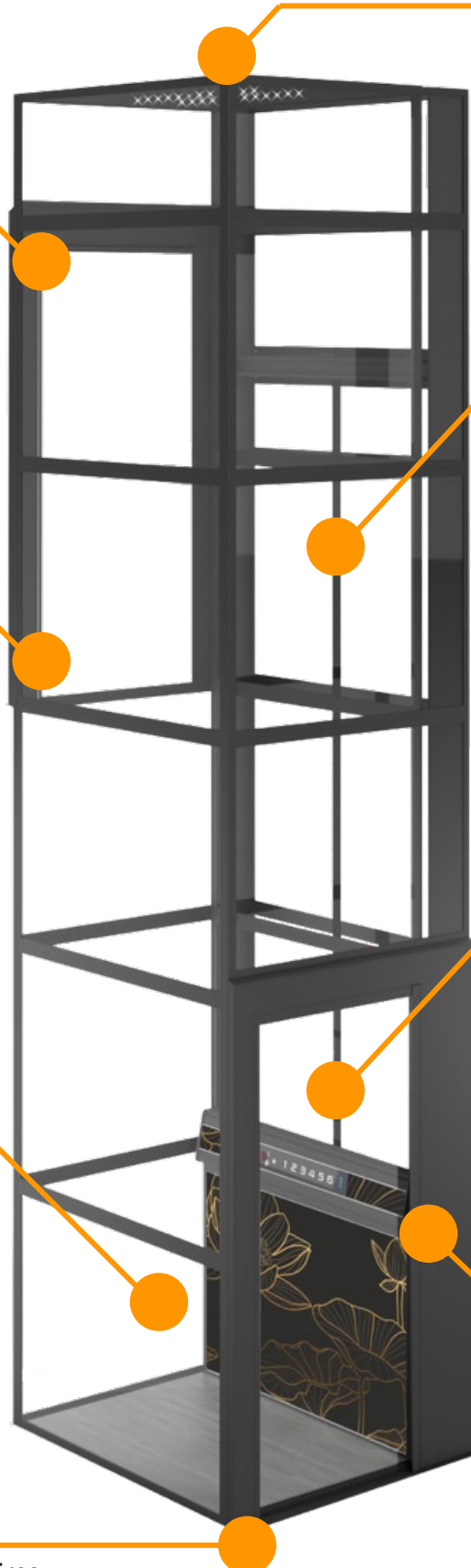

HISTORY OF SCREW - DRIVE SCREW-DRIVE GENERATIONS

- **Reduced oil use:** no oil on guiderails, auto-lubricating system on screw, >200 mL of oil / year!
- **More energy savings:** 1.5 kW motor
- **Silent operation:** new screw pitch and silent box for sound as low as 40 dB
- **Reduced maintenance:** as low as once per year

Includes all
2nd Generation / Smart Lift features



- **Mechanical System:** all functions were mechanical and not driven by software
- **Lower Travel Height:** 13 m

1st generation lifts were **discontinued**
in 2017 for all Cibes Lift Group
products



Invented for the Russian empress Catherine the Great by inventor Ivan Kulibin, the 1st screw drive elevator was installed in the imperial palace The Hermitage in St. Petersburg

2019



- **Smart Operating System:** digital OS (i.e. software)
- **Safer Lift** – thanks to our CiCon System, our lift can be SIL-3 certified, the second highest Safety Integrity Level there is
- **Reset RFID Tag** – you can reset the lift yourself – no need to wait for one of our technicians
- **Warning Systems:** e.g. low battery system
- **Fault and Breakage Record:** keeps track of all key metrics e.g. travel distance, number of faults and reason to help improve repairs
- **Higher Travel height:** from 13 to 20 m!
- **Advanced Features:** e.g. floor specific locks

2017



1990s

CIBES LIFT is founded in 1947, originally manufacturing goods lifts but quickly evolving into the accessibility and home lifts segment.

1947

1793

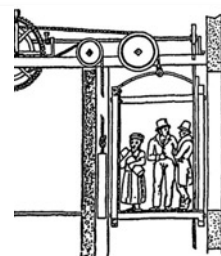

1st SCREW-DRIVE
ELEVATOR

SAFETY IS IN OUR DNA

SWEDISH FOCUS ON QUALITY

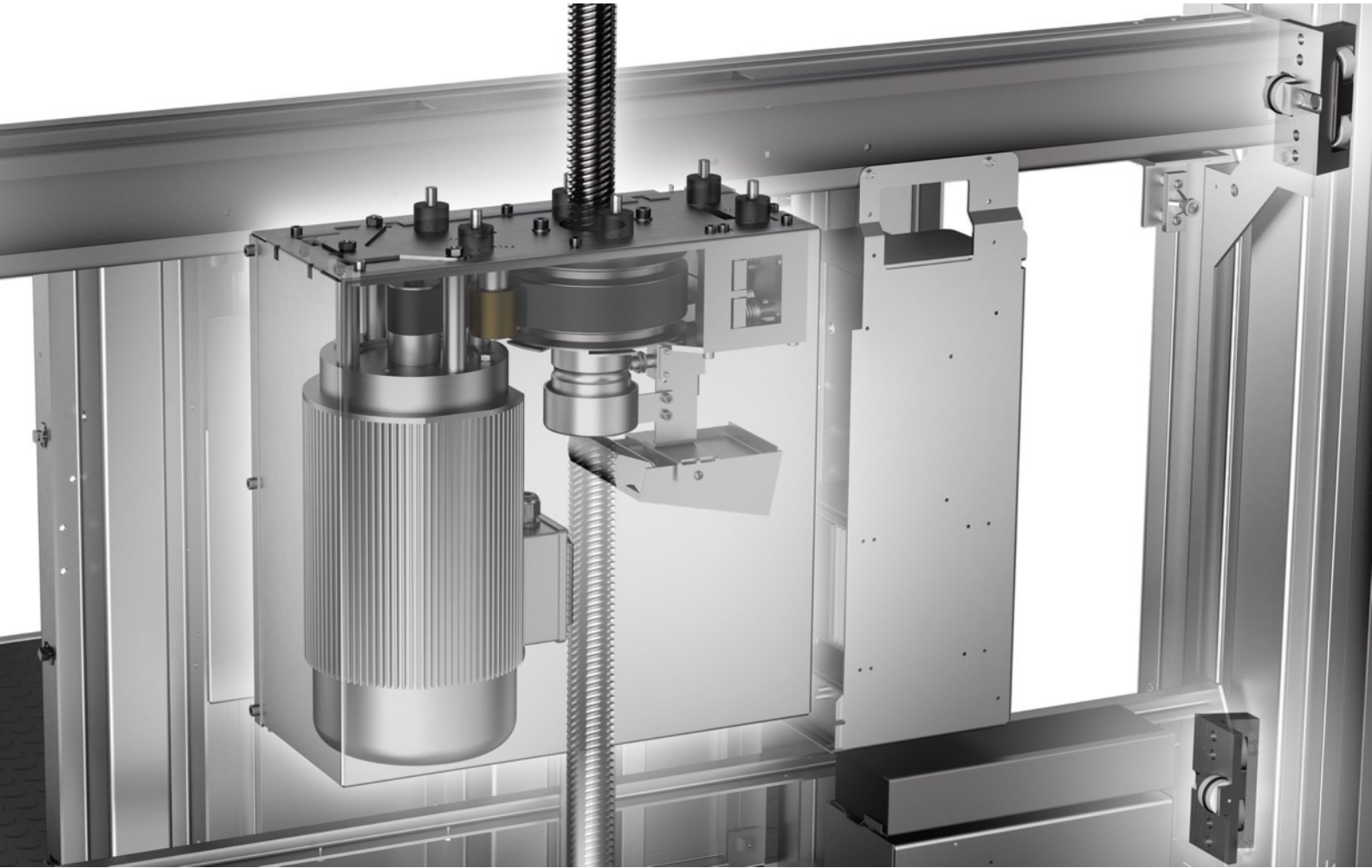

SCREW DRIVE TECHNOLOGY:

LIFTS THAT CANNOT “FALL DOWN”

Screw-drive technology is unique in the market in that the lifting cabin or platform is always attached to a toughened steel screw. The movement behind the “lifting” is not a pulling motion through cable or belt, but a rotation of a nut around the screw.

This revolutionary system ensures that Cibes Lift platforms and cabin cannot be “cut off” or enter freefall because of cable and brake failures. Instead, they are always connected to the steel screw that runs the length of the whole device.

Thanks to this technology, our screw drives are able to meet not only the extremely high European Safety Standards but also those of our other markets around the world, including but not limited to the USA and Australia.

WHY CUSTOMERS CHOOSE CIBES

OUR SAFETY STANDARDS



STANDARDS

All our lifts not only follow the strictest of European and international standards, but we even strive to respect recommended local standards in each of our markets.



SAFETY CERTIFICATIONS

Beyond certifying every lift with the European Lift Instituut, a certification agency specialized in lifts, all our lifts are **Safety Level Integrity 3** certified and our production **ISO 9001**



NATIONWIDE, 24/7 COVERAGE

We may be a global company, but we are hyperlocal for our customers. Our hotline is 24/7, with technicians spread across the country. We are there anytime, anywhere.



ANTI-TRAP SYSTEM FOR EMERGENCIES

All our lifts are equipped not only with an emergency battery lowering system in case of power failures, but also a reset system. Gen 4 also has manual lowering in pit!



PACKED WITH SAFETY SENSORS & FEATURES

The Cibes Voyager platform provides 360° catchment protection thanks to its safety bar, safety edges and safety stop button.

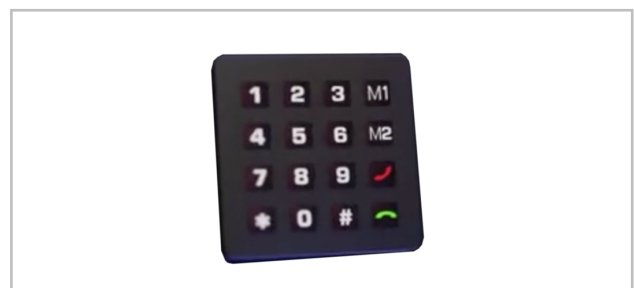

PHONE SYSTEM W/ PRE-PROGRAMMED HOTLINE

Every Cibes Air and Cibes Voyager comes equipped with a dialpad phone that can call our hotline in case of emergencies.

WHY CUSTOMERS CHOOSE CIBES

MEET OUR AFTER SALES TEAM



All our customers agree – the main reason to choose a Cibes lift is not our cutting-edge products or our expert sales team – **it is the quality of our After Sales Service.**

As soon as you book your lift with us, you will be entrusted to our Customer Care team with your appointed representative. They will ensure that:

BEFORE INSTALLATION

- Liaising with your construction team to prepare site & delivery
- Checking that site is correctly prepared and ready for installation

AFTER INSTALLATION

- Checking that installation is in line with our strict quality standards
- Delivering handover and product training on how to use your lift

... AND FOR THE DECADES TO COME

- Tracking and arranging timely maintenances
- Coordinating repairs, spare parts & fixes (if needed)
- Handling any customer requests / upgrades and more!

Mylen – Head of Customer Care

How do we know that our customers love our Customer Care Team?

Referrals are 35% of our new business!



CIBES 1 + 1 + 10 PROGRAM

So confident are we in the quality of our products that we offer a comprehensive 1+1+10 product guarantee.

1 YEAR OF FREE WARRANTY

The only thing more stressful than buying a lift is probably worrying about repairs and problems.

With Cibes, that worry does not exist.

We know that the quality of our materials, craftsmanship and installation creates a one-of-a-kind lift that will last for decades.

In fact, we are even willing to guarantee it, with a FREE 1 year warranty for every single Air or Voyager Cibes Lift that we sell.

Welcome to a new level of worry-free living. Welcome to the Cibes family!

1 YEAR OF FREE MAINTENANCE

Even more important than the warranty is the hidden cost of maintenance. With Cibes, there are no hidden costs: we offer 1 year of maintenance for FREE to every single Cibes Air or Cibes Voyager.

No last-minute additions for labor or spare parts – at Cibes, we want to provide our customers with complete peace of mind.

Most importantly, a Cibes maintenance is no small thing: we only use genuine Cibes Technology™ products, included Cibes Genuine High Performance Oil and Cibes Universal Contact Spray, to ensure that your lift continues to operate smoothly for decades!

10 YEARS OF FREE WARRANTY



on the Cibes Lift Screw & Nut, conditional to doing maintenances with Cibes Team timely throughout this period





CIBES
CIBES LIFT

HOME LIFTS

PLATFORM LIFTS

100% MADE IN SWEDEN

CIBES AIR



AIR METAL

Simple and aesthetic with a touchscreen – elegance personified



AIR TEXTILE

20+ light up design panels to choose from to perfectly match any home



AIR WOOD

2 laser-etched lighting options in RGBW complete with LiT shaft

MULTI-FACTORY OPTIONS CIBES VOYAGER



ELEGANCE

Simple and aesthetic with a touchscreen – elegance personified



AURORA

20+ light up design panels to choose from to perfectly match any home



GALAXY

2 laser-etched lighting options in RGBW complete with LiT shaft



ENTRY-LEVEL RANGE
CIBES AIR

CIBES AIR METAL

ENTRY-LEVEL



CIBES AIR METAL PLATFORM

FINISHINGS



CIBES AIR METAL

1000 Glass Panels

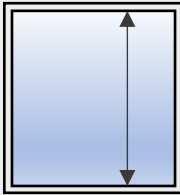

Over 25 Premium Powdercoats



AL5 Glass Max Door

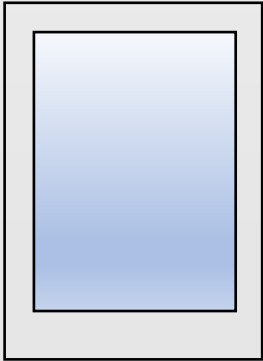

Handrail Control



Handset Phone



Emergency Stop Button



Built-In Floor Level Ind.

TECHNOLOGY



Screw Drive



EcoSilent



European EN81-41

CIBES AIR TEXTILE

MID-TIER

CIBES AIR TEXTILE PLATFORM



CIBES AIR TEXTILE

FINISHINGS

1000 Glass Panels

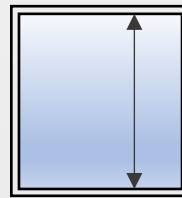

AL5 Glass Max Door

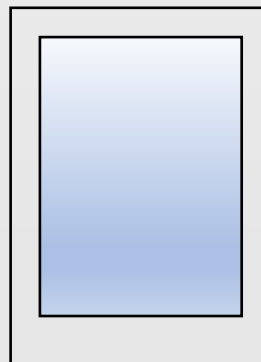

LINEN

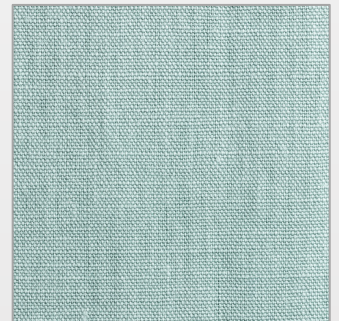

WOOL



Handrail Control



Light Up Central Panel



Handset Phone



Emergency Stop Button

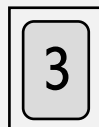

Built-In Floor Level Ind.

TECHNOLOGY



Screw Drive



EcoSilent



European EN81-41

CIBES AIR WOOD

TOP OF THE LINE



CIBES AIR WOOD PLATFORM

FINISHINGS



CIBES AIR WOOD

1000 Glass Panels

OAK

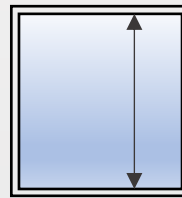

AL5 Glass Max Door

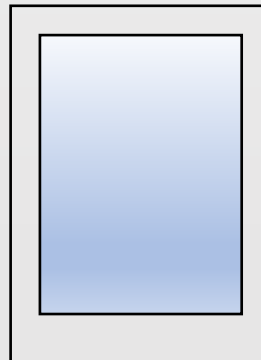

BAMBOO



Handrail Control



Light Up Acrylic Panel



Handset Phone



Emergency Stop Button



Light Up Safety Edge

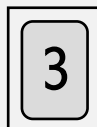

Built-In Floor Level Ind.

TECHNOLOGY



Screw Drive



EcoSilent



European EN81-41



TOUCHSCREEN RANGE
CIBES VOYAGER

ELEGANCE



ELEGANCE PLATFORM



ELEGANCE FEATURES



Touchscreen



Dialpad Phone



Emergency Stop Button



Compact Handrail

ELEGANCE SHAFT

1000 Glass Panels

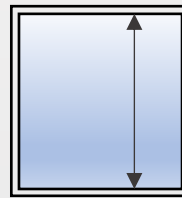

AL5 Glass Max Door

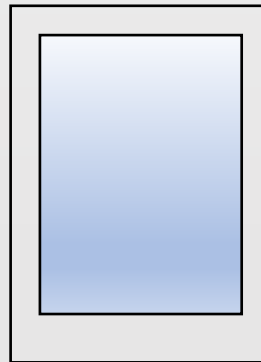

TECHNOLOGY



Screw Drive



EcoSilent



European EN81-41

AURORA



AURORA PLATFORM

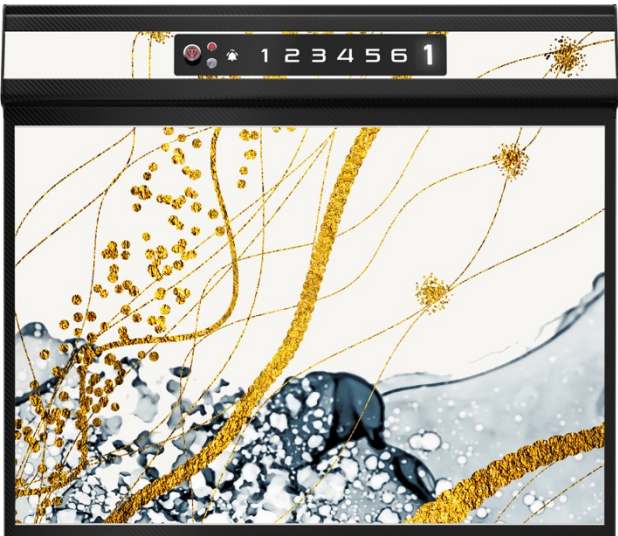

AURORA SHAFT

1200 Glass Panels

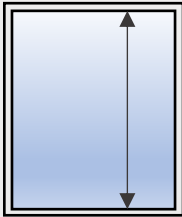

AL6 Glass Max Door

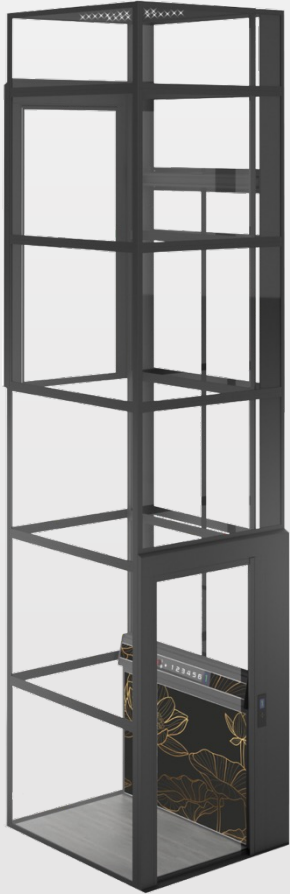
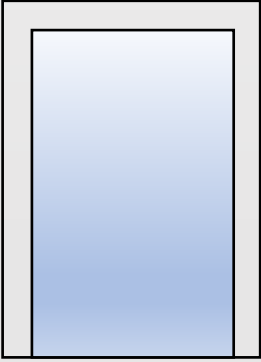

AURORA FEATURES



Touchscreen



Light Up Acrylic Panel



Dialpad Phone



Emergency Stop Button



Built-In Floor Level Ind.



Compact Handrail

TECHNOLOGY



Screw Drive



EcoSilent



European EN81-41



MINERAL SERIES - SANDSTONE CANYON



MINERAL SERIES - COBALT BLUE



GEOMETRY SERIES - VERONA



GEOMETRY SERIES - YEREVAN



MINERAL SERIES - GOLDEN TOPAZ



MINERAL SERIES - EVENING AGATE



GEOMETRY SERIES - INCA



GEOMETRY SERIES - EULER



MINERAL SERIES - NOVA CLOUDS



MINERAL SERIES - CLAY PARFAIT

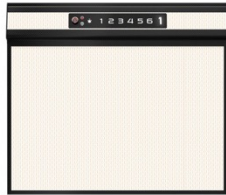

GEOMETRY SERIES - NEW ORLEANS



WATERCOLOR SERIES - TUSCAN SUN



MINERAL SERIES - BASILICA MARBLE



MINERAL SERIES - CINNABAR ROSE



CULTURE SERIES - LONG SPRING



CULTURE SERIES - DRAGON SEA



MINERAL SERIES - IMPERIAL BLACK



GEOMETRY SERIES - IONA



CULTURE SERIES - SEVEN ISLAND



CULTURE SERIES - PAVONA FEATHERS



20 unique light-up patterns to choose from!

GALAXY

GALAXY PLATFORM



GALAXY FEATURES



Touchscreen



Laser-Etched Design



Dialpad Phone



Emergency Stop Button



Built-In Floor Level Ind.

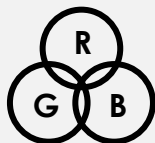

RGBW Lighting

GALAXY SHAFT

1200 Glass Panels

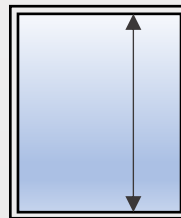

AL6 Glass Max Door

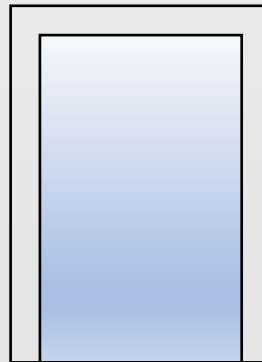

TECHNOLOGY



Screw Drive



EcoSilent



European EN81-41

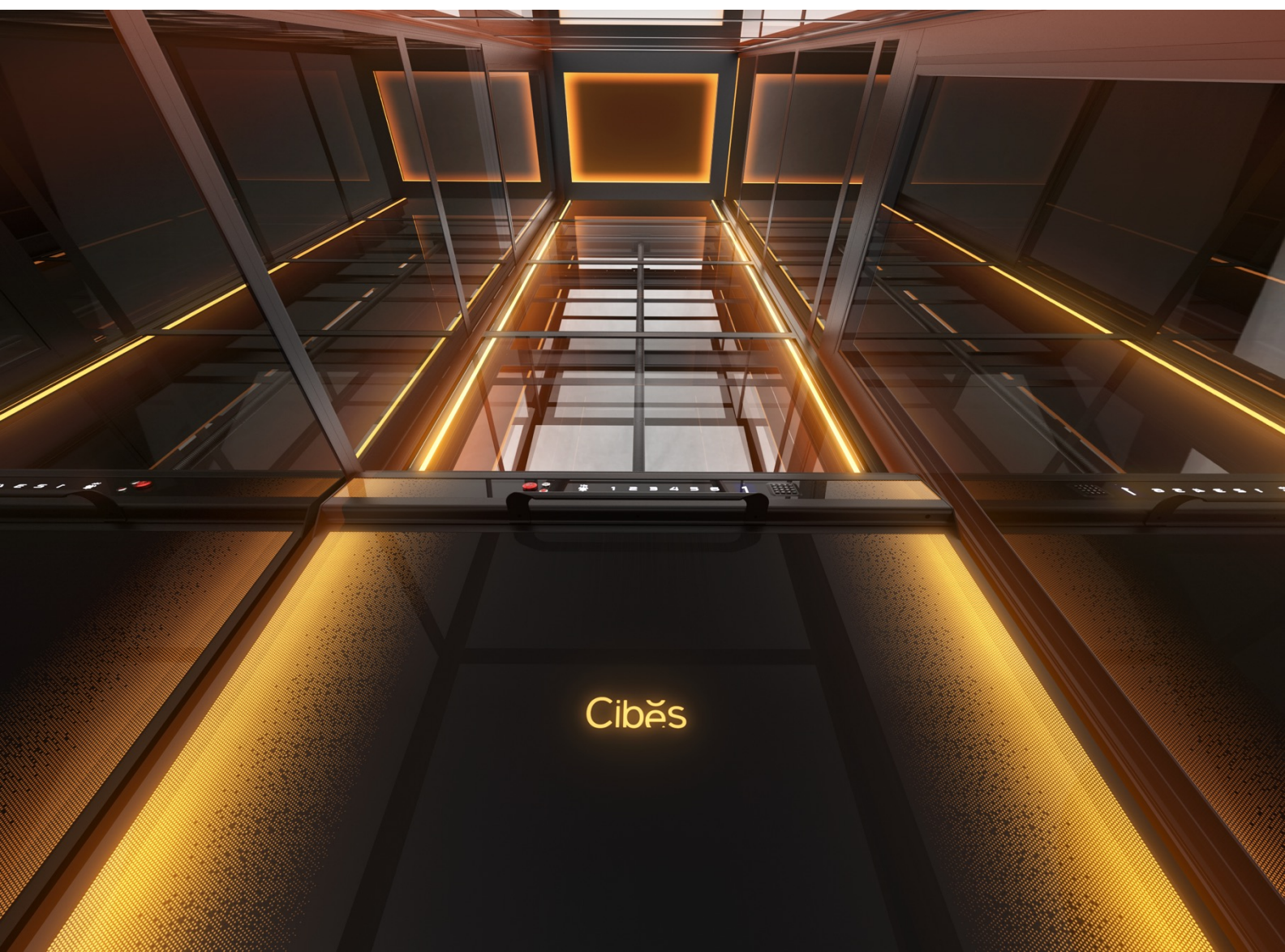

CUSTOMIZATION AND SIZES

	Platform Size (in mm)		Shaft Size (in mm)		Cut Out Size (in mm)	
	Width	Depth	Width	Depth	Width	Depth
XS	600	830	960	872	1020	980
S1	800	830	1160	872	1220	980
S2	900	830	1260	872	1320	980
S3	1000	830	1360	872	1420	980
S4	800	930	1160	972	1220	1080
S5	900	930	1260	972	1320	1080
S6	1000	930	1360	972	1420	1080
S7	1100	930	1460	972	1520	1080
M1	800	1217	1160	1259	1220	1380
M2	900	1217	1260	1259	1320	1380
M3	1000	1267	1360	1309	1420	1430
M4	1000	1367	1360	1409	1420	1530
L1	1100	1367	1460	1409	1520	1530
L2	900	1467	1260	1509	1320	1630
L3	1000	1467	1360	1509	1420	1630
L4	1100	1467	1460	1509	1520	1630
XL	1100	1597	1460	1639	1520	1760

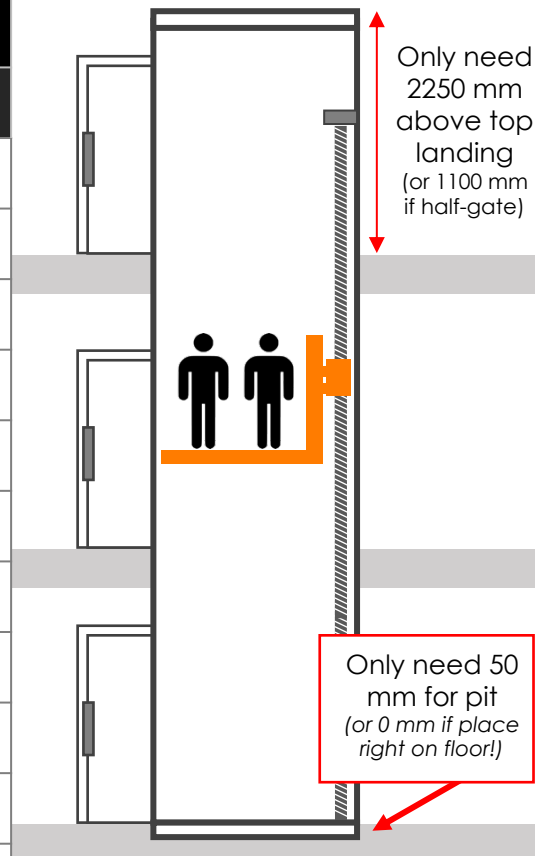

Premium Colors

Choose amongst our range of premium powdercoats with matte, metallic and sparkly finishes



Premium Carpets

Wood Series



Carpet Series



TECHNICAL SPECIFICATIONS

MAX # OF STOPS	6 Stops
POWER SUPPLY	1 phase 220V / 3 phase 220 V / 3 phase 400 V
MINIMUM HEIGHT TOP FLOOR	2250 mm (1100 / 1300 optional with half gate)
BOTTOM PIT REQUIREMENTS	60-70 mm / 0 mm optional with ramp
PRODUCT STANDARD	MD 2006/42/EC, EN81-41, certified by SIL3
DRIVE MODE	Screw-Drive
RATED POWER	1500 W (EcoSilent) / 2200 (Gen. 2)
MACHINE ROOM	None (integrated solution)
DOOR OPENING DIRECTION	Flexible choice for 3 sides
SAFETY DEVICE	360° catchment protection. Emergency Battery Lowering in case of power failure. Overload alarm device. Emergency communication device. Electronic and mechanical safety door protection system. Can be connected to fire alarm device.
SHAFT OPTION	Steel Panels with option for laminated glass on 5 sides
INSTALLATION LOCATION	Indoor or outdoor

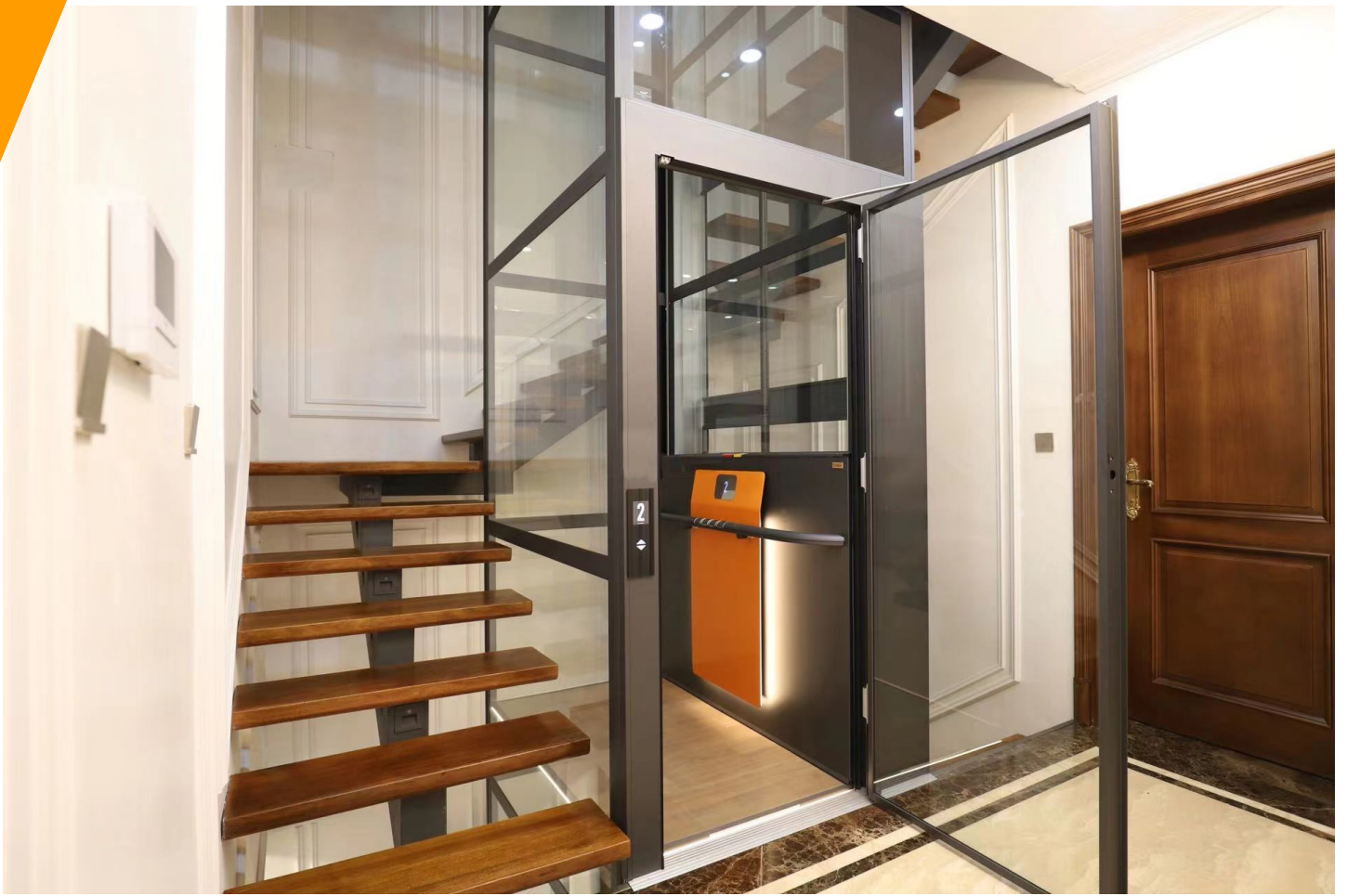

CIBES AIR INSTALLATIONS



VOYAGER ELEGANCE
INSTALLATIONS

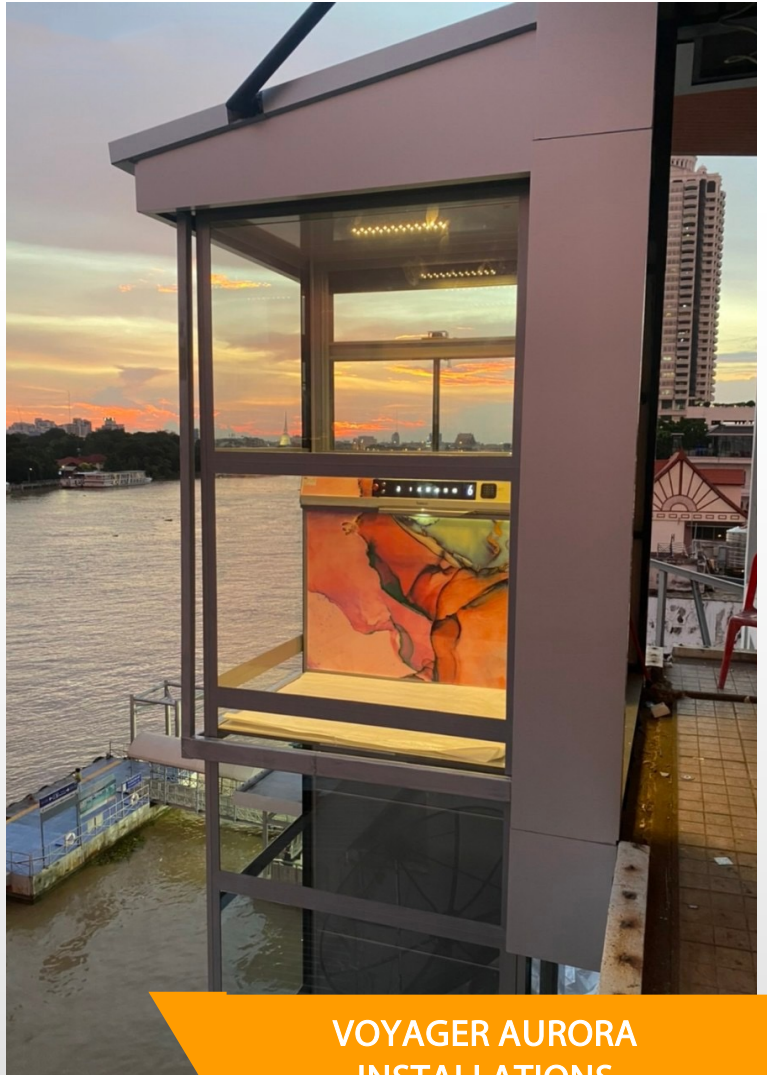

**VOYAGER AURORA
INSTALLATIONS**

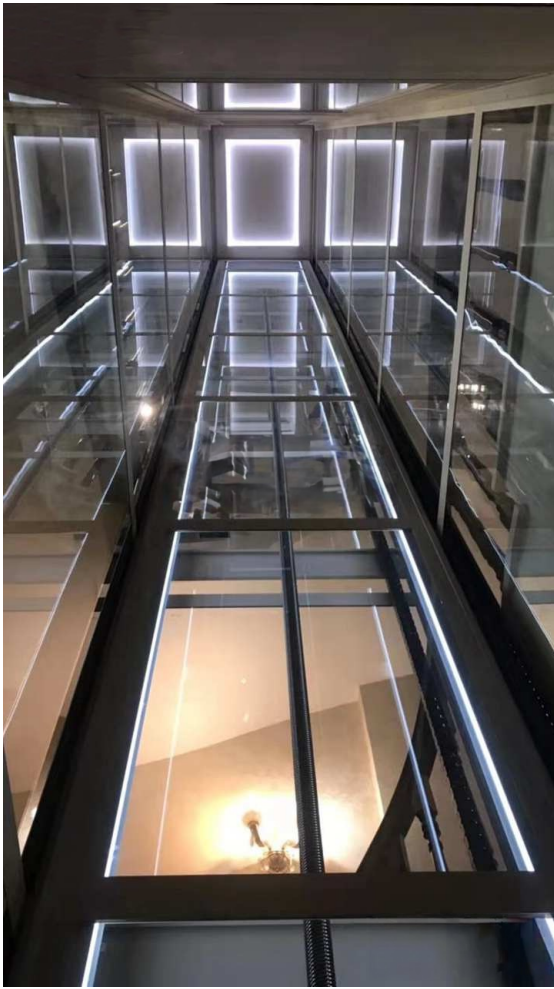

VOYAGER GALAXY
INSTALLATIONS

OUR KEY DIFFERENCE

EXCEPTIONAL AFTER-SALES



THE FACTORY-DIRECT AFTER-SALES PROMISE

Cibes Lift Philippines Inc. knows that the secret to its phenomenal success has been its best-in-class after-sales service. Over 35% of our business comes from referrals. This is because Cibes has focused on a factory-direct strategy for its technical team as well:

- NO OUTSOURCING!
- TECHNICIANS TRAINED FROM SWEDEN
- LOCAL SPARE PARTS WAREHOUSE

OUR AFTERSALES IN THE PHILIPPINES

AFTER SALES TEAM

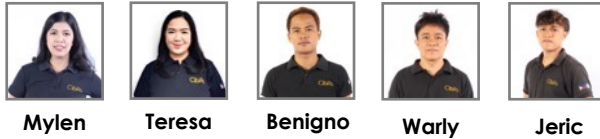

POST SALES TEAM



TECH TEAM

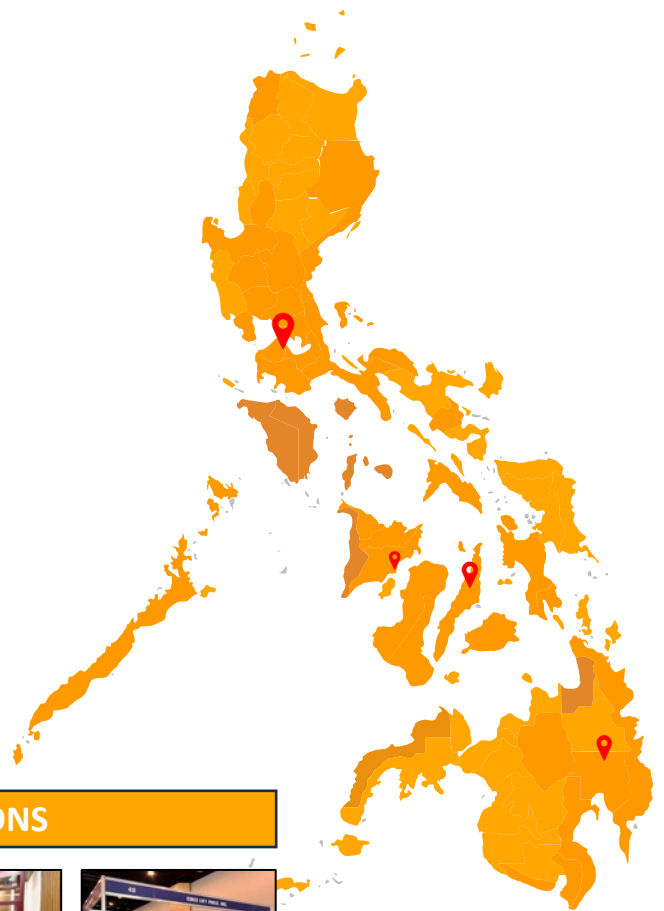
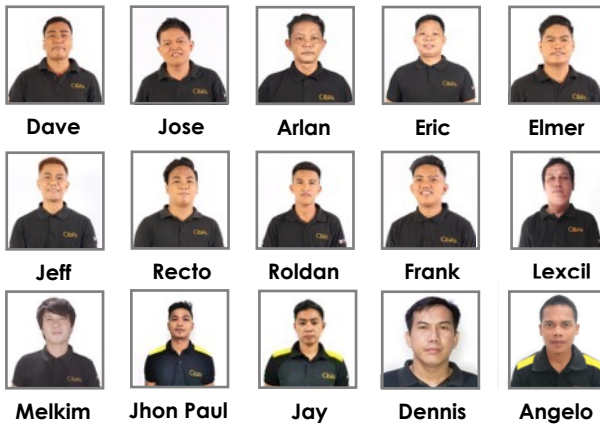

SHOWROOMS & TECHNICAL STATIONS



MAKATI



MANDALUYONG



CEBU

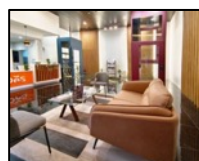

DAVAO



ILOILO

NATIONWIDE
COVERAGE

Ciběš